

TOUCH LS

15 / 20 / 30

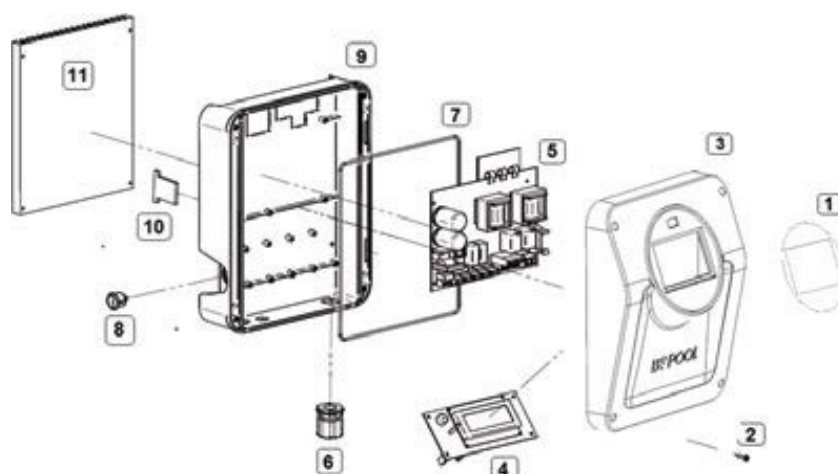

GRÁFICO
GRAPHIC

	Referencia / Reference	Descripción / Description	Observaciones / Notes
1	CARÁTULA-TOUCHLS	Teclado / Keyboard	✓
2	424RFAH	Tornillos tapa / Cover screws	✓
3	TOUCH*-TAPA	Tapa / Cover	✓
4	P906-9	Placa de control / Control board	✓
4 ^a	P906/9-LEDS	Placa de relés / Relays board	✓
5	P950/3	Placa de potencia / Power board	TOUCHLS15
5a	P972	Placa de relés / Relays board	✓
5b	P953/2	Placa de potencia / Power board	TOUCHLS20
5c	P963 V2	Placa de potencia / Power board	TOUCHLS30
6	M25JSL-N	Prensaestopas / Compression gland	✓
6a	M20JSL-N	Prensaestopas / Compression gland	✓
6b	M12 JSL-N	Prensaestopas / Compression gland	✓
6c	SP1312/S2C	Conector pH / pH Connector	✓
7	JUNTA 01	Junta / Waterproof seal	✓
8	R13112AAA	Interruptor / Switch	✓
8a	F0188LOAAA	Protector de interruptor / Switch protector	✓
9	EVO-BASE-N	Base caja EVO / EVO base box	✓
10	BISAGRA-GOMA	Bisagra / Hinge strap	EVOBASIC35
11	KK200/233/M/K-EVO	Radiador / Heatsink	TOUCHLS15
11a	KK200/270/M/K-EVO	Radiador / Heatsink	TOUCHLS20
11b	KK200/233/M/K-BSONE	Radiador / Heatsink	TOUCHLS30