

# N-BSSALT

## 10 / 15 / 20 / 25 / 35

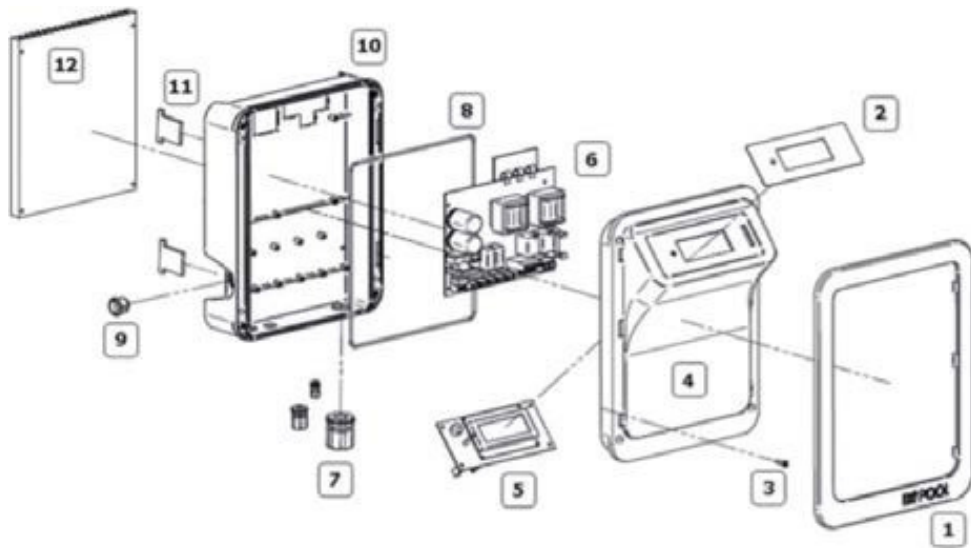

GRÁFICO  
GRAPHIC

	Referencia / Reference	Descripción / Description	Observaciones / Notes
1	EVO2-EM-V	Embellecedor / Frame	✓
2	TECLADO-BSSALT-D	Teclado / Keyboard	✓
3	424RFAH	Tornillos tapa / Cover screws	✓
4	EVO 2-TAPA-N	Tapa / Cover	✓
5	P909-7	Placa de control / Control board	✓
6	P927-4	Placa de potencia / Power board	N-BSSALT10 - 15
6a	P950-3	Placa de potencia / Power board	N-BSSALT20 - 25
6b	P953-2	Placa de potencia / Power board	N-BSSALT35
7	M25JSL-N	Prensaestopas / Compression gland	✓
7a	M20JSL-N	Prensaestopas / Compression gland	✓
8	JUNTA 01	Junta / Waterproof seal	✓
9	R13112AAA	Interruptor / Switch	✓
9a	F0188LOAAA	Protector de interruptor / Switch protector	✓
10	10 EVO-BASE-N	Base caja EVO / EVO base box	✓
11	BISAGRA-GOMA	Bisagra / Hinge strap	✓
12	KPA200/228/EVO	Radiador / Heatsink	N-BSSALT10 - 15
12a	KK200/233/M/K-EVO	Radiador / Heatsink	N-BSSALT20 - 25
12b	KK200/233/M/K-EVO	Radiador / Heatsink	N-BSSALT35